

Frangible Pin System

SPORT &
COMPETITION



INSTALLATION &
MAINTENANCE INSTRUCTIONS

READ THESE INSTRUCTIONS BEFORE OPERATING THE SYSTEM

British Eventing Limited

Stoneleigh Park
Kenilworth
Warwickshire
CV8 2RN

Telephone: 0845 262 3344

Fax: 0247 669 7235

Email: info@britisheventing.com

Web: www.britisheventing.com



Installation and Maintenance Instructions

Frangible Pin System

Device Type:	Frangible Pin
FEI License Number:	Short FEI03GBR Long FEI04GBR
Document number:	BE/Frangible Pin/V1.02
Date of release:	April 2013

Original Instructions

This installation and maintenance instruction includes important safety information and instructions for installation and maintenance of the **Frangible Pin System**. It is essential therefore, that the responsible specialist refers to it before starting any work on the system as well as prior to installation.

This page has been deliberately left blank.

Contents

1	<i>Introduction</i>	4
1.1	General description	4
1.2	Application	5
1.3	System details	7
1.3.1	Operating instructions	7
1.3.2	Manufacture	7
1.3.3	Range, size and version	7
1.3.4	FEI License number	7
1.3.5	Release date and version of operating instructions	7
1.3.6	Modifications	7
	Component identification	8
1.3.7	Component parts	8
1.3.8	Specialist tools	9
2	<i>Safety</i>	10
3	<i>Installation</i>	11
3.1	Installation process	11
3.2	Conventional pinning (rail on take-off side of fence)	14
3.3	Reverse pinning (rail on landing side of fence)	15
4	<i>Replacement of frangible pins</i>	19
4.1	Fatigue indication	20
5	<i>Range of configurations</i>	21
6	<i>Troubleshooting</i>	26
7	<i>Disposal of safety equipment</i>	28
8	<i>Storage / maintenance</i>	28

1 Introduction

This instruction manual (BE/Frangible Pin/V1.01) supersedes all existing manuals referring to the installation and operation of frangible pin systems and combines instructions for conventional pinned fences and the more recent method of reverse pinned fences.

Frangible pins are currently used at events governed by British Eventing (BE) and the Fédération Equestre Internationale (FEI) where it is the responsibility of the Technical Advisor (TA) or the Technical delegate (TD) for the respective events to ensure the correct installation and operation of the frangible pins.

1.1 General description

The frangible pin is a safety device designed to limit force in the event of a horse impacting a fence. In the event that the pin is subjected to a force greater than the design limit it will bend and fail at the design point. The frangible pin can be fitted to a range of post and rail fences described in this installation document. It may also be fitted to other fences that allow a clear vertical drop of at least 400mm, however these must be approved by the event official.

The pin can be fitted in two ways, conventionally with the rail on the take-off side or reverse with the rail on the landing side of the posts. This instruction document describes both methods of fitting. The method used is open to the discretion of the course designer and builder and may be influenced by the governing body of the sport.

Correct installation and regular inspection of the pins is vital to ensure correct operation.

1.2 Application

The Frangible Pin is designed to be used in certain types of cross country obstacle to improve safety for the horse and rider. It is vital that the instructions are read and understood by all who use the system. Failure to abide by these instructions could result in:



- Increased risk to the rider
- Increased risk to the horse
- Injury to equipment operative
- Injury to bystanders / spectators

IMPORTANT

The use of a frangible pin, in any format, does not guarantee the prevention of serious or fatal riding accidents in cross country competition or training.

Even with a properly fitted system in place it is still possible for a serious or fatal accident to occur at a cross country obstacle.

The Frangible Pin can be fitted in two ways; conventional pinning or reverse pinning. Table 1 lists key details for the application of the two techniques.

	Conventional Pins	Reverse Pins
Fence layout	Top rail positioned on pins on the take-off side of the posts	Top rail positioned on pins on the landing side of the posts
Concept of operation	Force limiting device, the pins fail under vertical load resulting from the initiation of a rotational fall. As the rail drops away the force is reduced.	Force limiting device, the pins fail under vertical load resulting from initiation of a rotational fall. As the rail drops away the force is reduced. The allowance of movement in the horizontal direction will reduce the force required to fail the device.
How to apply	The frangible pin system can be fitted to any suitable post and rail fence as approved by a TA/TD in either configuration (conventional or reverse).	
Activation	Activates when the vertical load on one pin exceeds 7.5 kN.	Activates when the vertical load on one pin exceeds 7.5 kN, design of cable means that horizontal load on the rail can increase vertical load so correct fitting and tensioning of the cable is important.
Installation assessment	Assessment by TA, TD or local equivalent.	
Replacement of system	If a pin shows any sign of deformation it should be replaced.	
Disposal of product	Failed pins should be disposed of and recycled responsibly.	Failed pins should be disposed of and recycled responsibly. Cable assemblies can be reused in most cases or sent for metal recycling.

Table 1 – Pinning type application

1.3 System details

1.3.1 Operating instructions

The document number BE/Frangible Pin/V1.01 assigns the operating instructions to a particular system. They are valid only for a system identical with that system indicated on the cover.

1.3.2 Manufacture

The Pins and Sleeves are manufactured from Aluminium to BS EN755

1.3.3 Range, size and version

Property	Value
Activation force	7500 Newtons
Activation energy	70 Joules
Fence Height	No Limit (Compulsory above 950mm)
Maximum width between pins	4800 mm
Rail diameter	160-250mm ¹
Maximum Rail mass	250 kg
Temperature range	Suitable at ambient temperature
Rail Drop	The rail must be free to drop at least 400 mm at each pin position on activation.

1.3.4 FEI License number

FEI Licensee Number: Short FEI03GBR
 Long FEI04GBR

1.3.5 Release date and version of operating instructions

April 2013
Version 1.02

1.3.6 Modifications

Modifications to any components are not permitted under any circumstances

¹ Timber of greater diameter can be used as long as the centre of the rail sits on the setting marker of the pin and that the overall weight of the rail does not exceed 250 kg. This can be achieved by notching the rail back onto the posts, but must be discussed with, and approved by, the technical advisor or technical delegate.

Component identification

1.3.7 Component parts

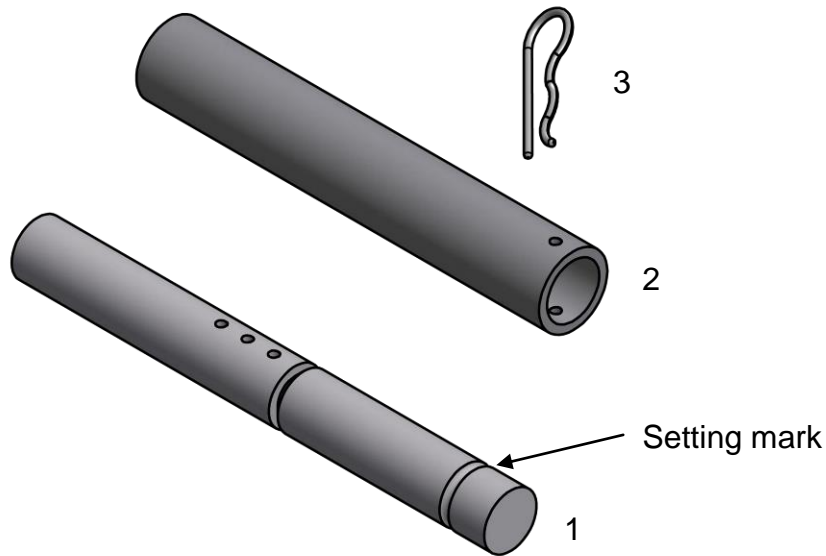

Figure 1 – Standard kit

1 – Frangible Pin

2 – Sleeve

3 – Retaining R type clip

4 – Rope (not shown, used to hold rail in place), must be at least 6mm diameter polypropylene

IMPORTANT

Frangible pins have a visual indicator in that by looking at the pin you can see if it is bent or has started to deform through the fracture point.

When there is any sign of bending or deformation the pin should be replaced.

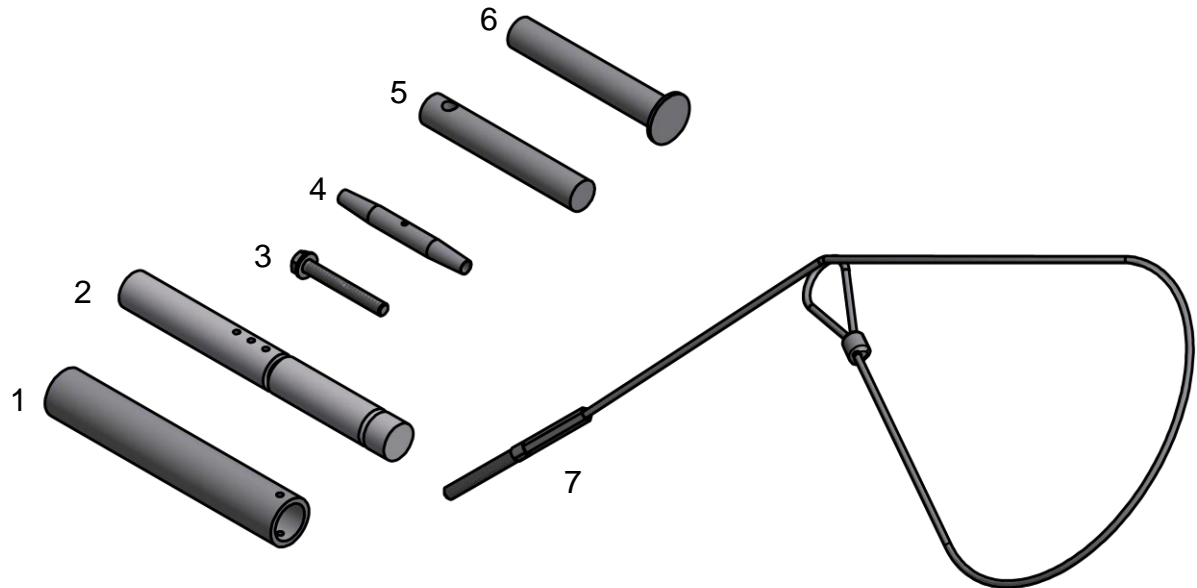

Figure 2 – Reverse pin kit

- 1 – Sleeve
- 2 – Frangible pin
- 3 – M10 Bolt and washer
- 4 – Turnbuckle body
- 5 – Anchor sleeve
- 6 – Pivot sleeve
- 7 – 5mm pre-fabricated stainless steel wire rope assembly

1.3.8 Specialist tools

Standard pinning:

- 37.9 mm diameter auger (with appropriate drill)
- Sleeve driving tool – suitable drift/block of wood

Reverse pin kit (as above plus):

- Torque wrench – 10 Nm torque setting with 17 mm socket
- 25mm wood auger

2 Safety

When fitting frangible pins and constructing fences in general it is important to work safely. Appropriate personal protective equipment (PPE) should be worn when working at all times. Particular attention should be paid when using power tools and lifting equipment to assemble fences.

IMPORTANT

- Always abide by local health and safety laws and regulations
- Always follow instructions provided with tools and lifting equipment
- Where necessary make sure appropriate training is undertaken before starting work
- Carry out appropriate risk assessment before commencing work

3 Installation

3.1 Installation process

IMPORTANT

The careful and accurate installation of the pins is essential to ensure the reliable activation of the system.

The TA / TD is responsible for checking the correct installation of the system prior to the start of competition.

Before commencing it is necessary to determine the overall fence dimensions and layout and if conventional pinning or reverse pinning is to be used.

1. Post installation

The posts should be installed vertically into the ground and be well secured, taking ground condition into consideration. The centre of the posts should not be more than 4800mm apart.

2. Sleeve installation

After determining the height of the fence, mark the position of the sleeve 20mm below the bottom of the rail and drill a 38mm hole **horizontally** all the way through the post.

Note: The hole must be horizontal to ensure correct operation of the pin. The hole diameter must not exceed 38mm to ensure that the sleeve is a tight fit in the timber.

After drilling, drive the sleeve into the hole from the rail side using a suitable drift or block of wood, ensuring the pin locking hole remains on the rail side of the fence (as shown in Figure 3). Do not hit the sleeve directly with a hammer, burring of the sleeve may prevent the smooth insertion of the pin.

Insert the sleeve until the pin locking hole is approximately 5mm from the post allowing the "R" clip to be inserted. If an excessive amount of sleeve is protruding on the other side of the post it may be desirable from a safety and aesthetic point view to cut off the excess sleeve and file down the edge to leave a smooth burr free finish. Repeat this process for the second post.

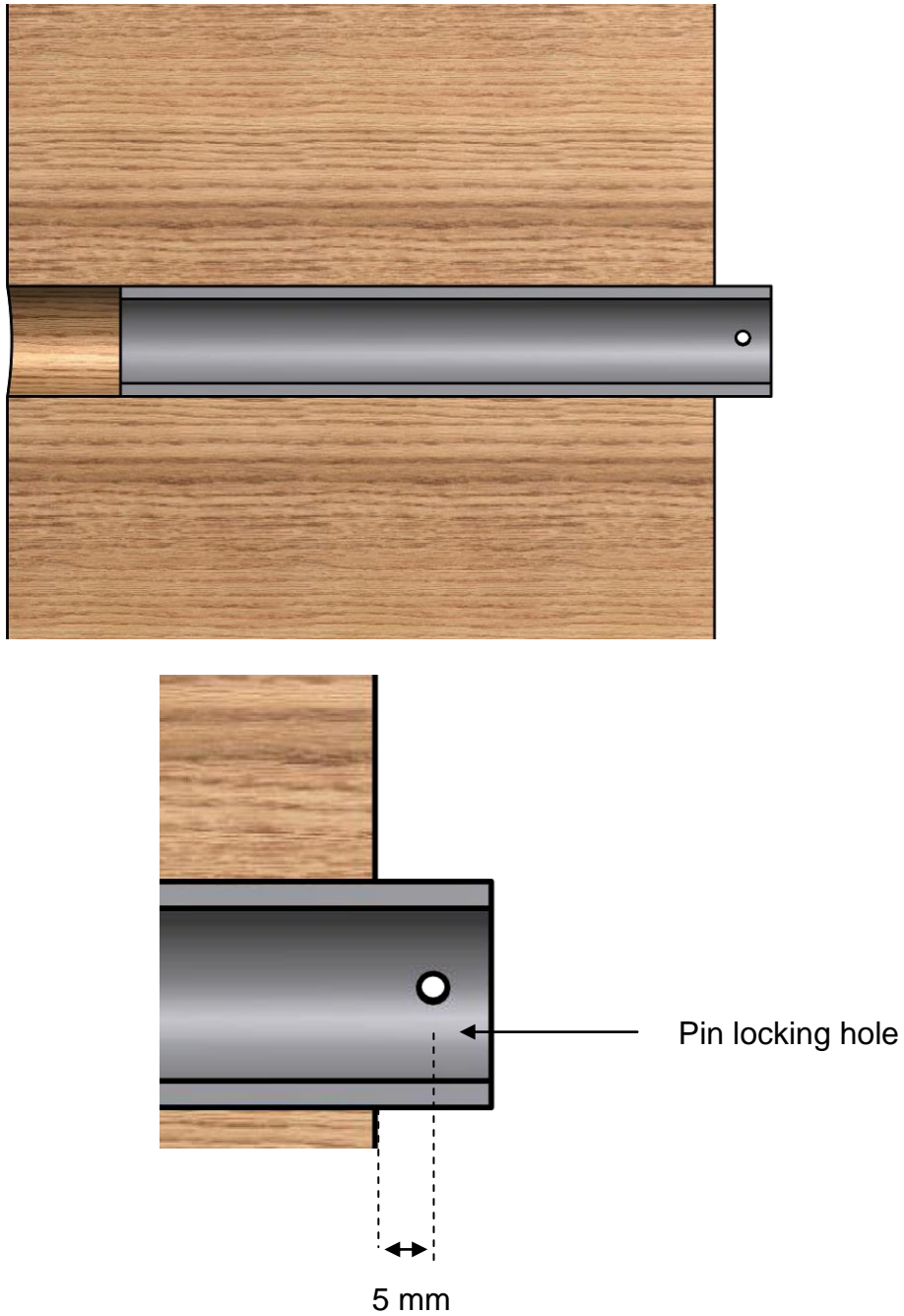

Figure 3 – Sleeve installation

3. Pin installation

Fit a pin in each of the sleeves ensuring that the pin is inserted in the correct direction as shown in Figure 4 (the angled notch and marking notch should be on the rail side of the post).

Use suitable lifting equipment to raise the rail into position. Very carefully (making sure that the rail is safely supported) adjust the position of the pin so that the setting mark of the pin is as close as possible to the centre line of the rail whilst lining up with one of the three hole positions.

Finally, lock the pin in position in the sleeve with "R" clip.

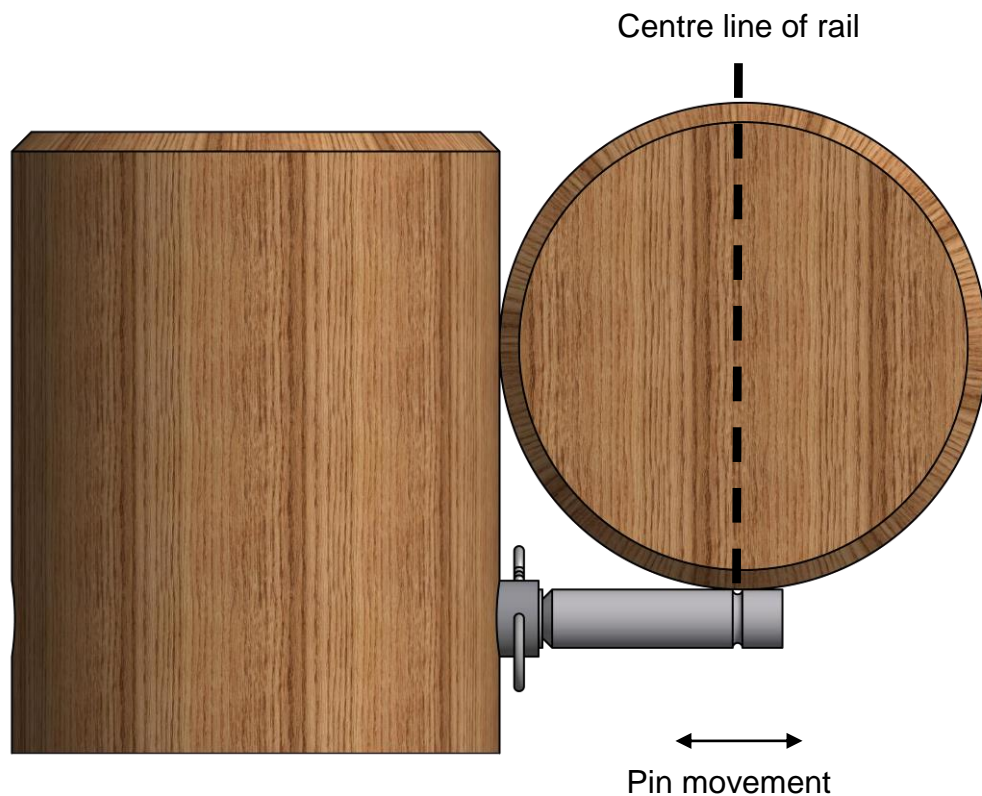

Figure 4 – Close up of pin installation

3.2 Conventional pinning (rail on take-off side of fence)

Starting point: Frangible pins and rail are fitted to the take-off side of the fence.

Rope the rail onto the pins ensuring that the rail is free to drop at least 400mm at each pin position when the pin breaks. Roping must be as tight as possible using suitable polypropylene rope of 6mm minimum diameter.

Once installed, remove the pin and check that the rail can drop freely at all points where installed.

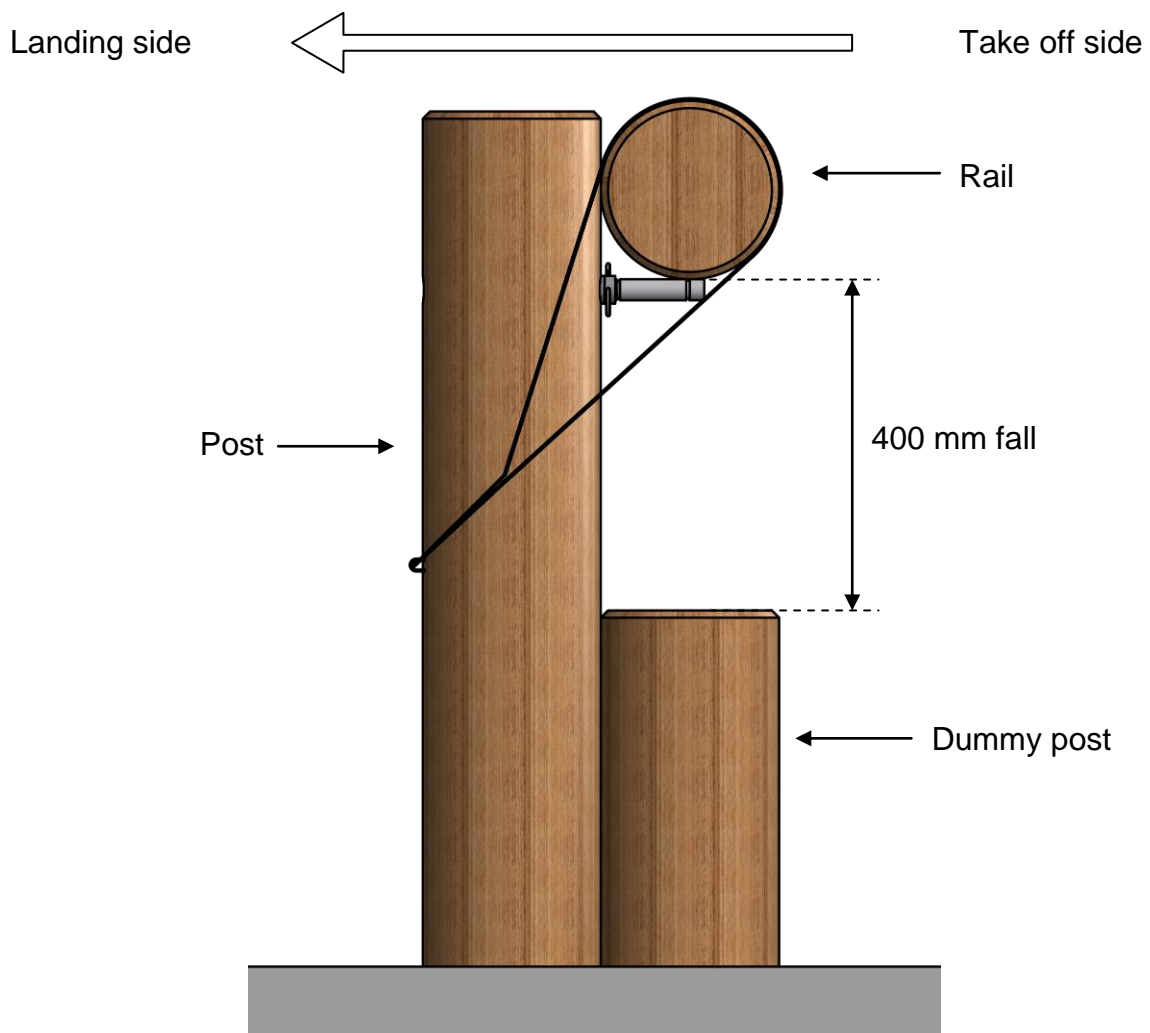

Figure 5 – Conventional pinning (only top rail shown)

3.3 Reverse pinning (rail on landing side of fence)

Starting point: Frangible pins and rail are fitted to the landing side of the fence.

1. Mark position of **pivot point dowel** as follows:
 - a. If rail diameter is 300mm or greater mark the centre of the pivot point 100mm below bottom of rail.
 - b. If rail diameter (D) is less than 300mm, mark the centre of the pivot point 250mm – (0.5 x D) below bottom of rail.

Example: 250mm rail (D = 250 mm), Pivot point = 250 – (0.5 x 250)

Pivot point = 125mm below bottom of rail allowing approximately 500mm drop height

Alternatively, the look up chart below can be used.

Rail diameter (mm)	Pivot sleeve position (mm)
150	175
175	162.5
200	150
225	137.5
250	125
275	112.5
300	100

Note 1: Rail diameter refers to the rail diameter where the restraint system is to be used.

Note 2: Pivot sleeve position is the vertical distance down the post from the underside of the rail when positioned on the frangible pin.

Note 3: For rail sizes 300mm and above, the pivot sleeve position is 100mm.

2. Using a 25mm wood auger (not flat wood bit) drill pivot point hole.
Note: drilling completely through post will allow removal with a drift.

3. Insert the **pivot dowel** with end flange into hole leaving approximately 15mm protruding from the post and hook the loop (soft loop) over flange as shown in Figure 6.
4. With rail in place, run the wire rope underneath and around the rail, back around the **pivot point dowel** and allow the rigging screw body to hang down the post.
5. Ensure that the 120mm stainless steel bolt is inserted by no more than 20mm and that the swaged stud is half way into the rigging body.
6. Ensure rail is against the posts, pull the steel rope system hand tight vertically down post and mark the post at the bottom of the stainless steel bolt.
7. Drill 25mm anchor point hole 30mm above the mark and insert **anchor dowel** leaving 35mm protruding from the post.
8. Remove bolt from rigging screw, lubricate with copper slip or similar, pass bolt through hole in **anchor dowel** and into rigging screw. An 80mm bolt is also provided to add extra flexibility.
9. Repeat process on other post.
10. Ensure rail is in correct position on the frangible pins. Tension restraint systems using torque wrench to 10Nm whilst holding the rigging screw with a suitable screwdriver in the centre hole.
11. Following tensioning, check each tensioning device with torque wrench to confirm correct torque has been maintained.

Note: The side of the post that the system is fitted to should be selected to minimise the risk of injury to the horse. If on the outside care should be taken to ensure the cable cannot slip off the rail in the event of pin failure.

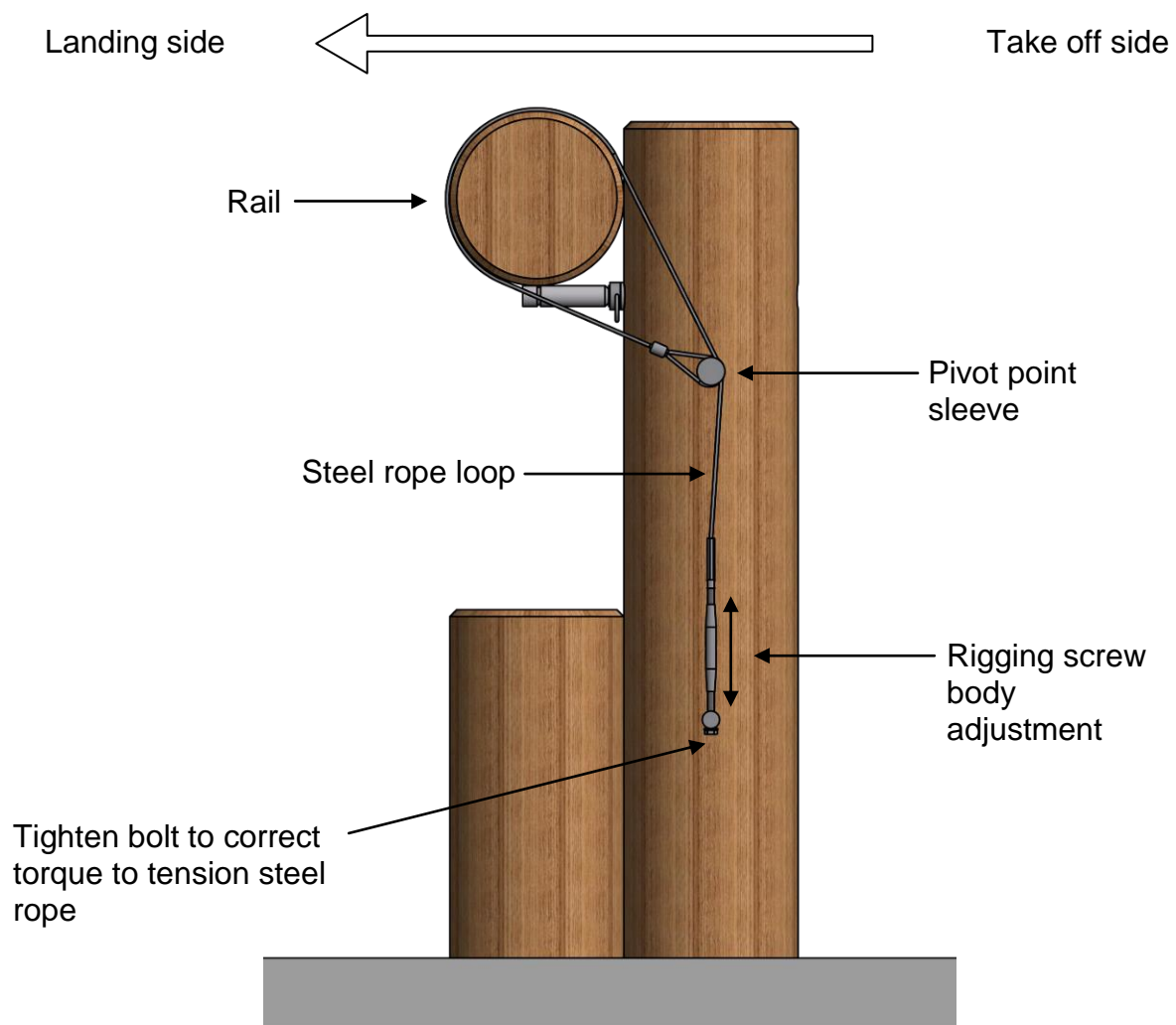

Figure 6 – Reverse pinning (only top rail shown)

Reverse pinning system notes:

1. This reverse pinning system is designed for round rails, careful consideration must be given before using on fences made from timber not of round cross section as the system may not be suitable.
2. It is essential that the rail drop is tested for each installation. This can be done by supporting the rail with a jack or suitable lifting equipment, loosening the system slightly, removing the pin and slowly lowering the rail. The height of the rail should reduce by a minimum of 400mm at each end when the pin is removed. It should be noted that if the system is fitted to the outside of the post, lowering of the rail at one end may cause the opposite pin to fail.
3. The effectiveness of the system is dependent on the correct installation and position of the pivot and anchor sleeves. It is important that they are installed to the correct depth in the correct size hole. The sleeves must be installed perpendicular to the rail to ensure correct alignment of the tensioning system.
4. If a frangible pin were to fail, it is important that the tensioning system is slackened allowing the rail to be re-positioned and a new pin inserted. The restraint system can then be re-tensioned for competition use.
5. If the system needs to be released simply undo the bottom bolt freeing the rigging screw.

4 Replacement of frangible pins

By their nature frangible pins are designed to fail. There are a number of situations where replacement may be required. It is important that preparations are made so that pins can be replaced quickly when required.

- Pins must be replaced when broken.
- Pins must be replaced when fatigue is indicated, see section 4.1.
- A pin will bend (not shear) if the fence is hit with a force approaching the pre-determined level at which the pin is designed to shear, see section 4.1.
- All pins should be visually checked regularly throughout the day of competition, and must always be checked immediately after the fence has been hit. This should be done initially by the Fence Judges, having been briefed by the TA/TD prior to the start of competition.
- Spare pins will be carried by the TA/TD or course builders.
- The TA/TD is responsible for ensuring all fence repair teams operating on the day of competition are supplied with an adequate number of replacement pins.

4.1 Fatigue indication

To maintain optimum performance of the system it is important that it is monitored for signs of fatigue that will cause the system to be activated below the intended threshold.

All pinned systems should be inspected in the following instances:
(Inspection should be done initially by the Fence Judges, having been briefed by the TA/TD prior to the start of competition.)

- a. Prior to the competition
- b. Regularly throughout the competition
- c. After any impact with a fence
- d. In the case that a system is partly activated all other parts of the system should be inspected

Fatigue is indicated by:

- a. The pin bending in such a way that it can be detected by visual inspection, see Figure 7.
- b. In the case of a reverse pin the pin bending will cause the tension on the cable to reduce such that the cable can be displaced by hand.



Figure 7 – A pin indicating fatigue by bending which is clearly visible

5 Range of configurations

This instruction manual provides instruction for the installation of the frangible pin system to a simple post and rail fence. Details are only given for the top rail of the fence that forms the frangible element of the system. It is however important to consider how the frangible element interfaces with the lower, non-frangible elements of the obstacle.

For both pinning systems (conventional and reverse), it is important that when a pin is activated, the fence reduces by 400mm at the position of the pin. Lower parts of the fence should not restrict the fall of the frangible element of the fence or be higher than the frangible element of the fence after activation. The tendency for fences to have an ascending profile means that this is less of a problem in reverse pinning but can be more difficult in conventional pinning.

Figure 8, Figure 9, Figure 10 and Figure 11 show common applications of pins in typical cross country obstacles.

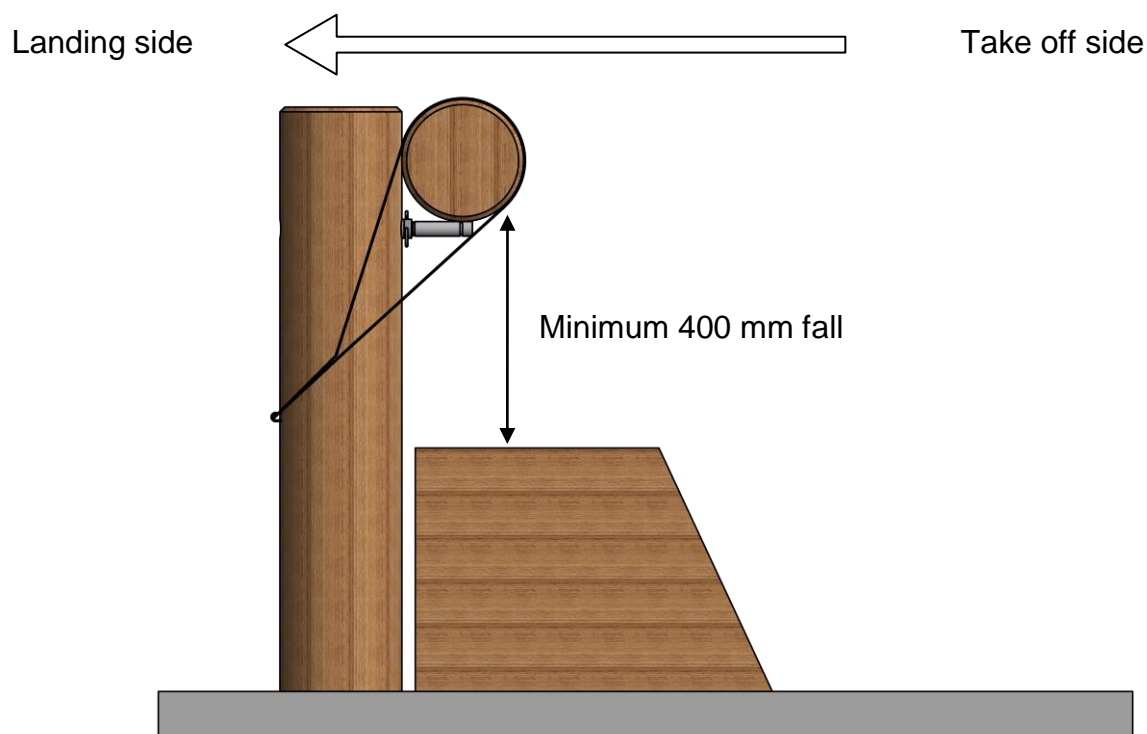

Figure 8 – Post and rail with filler (flower box)

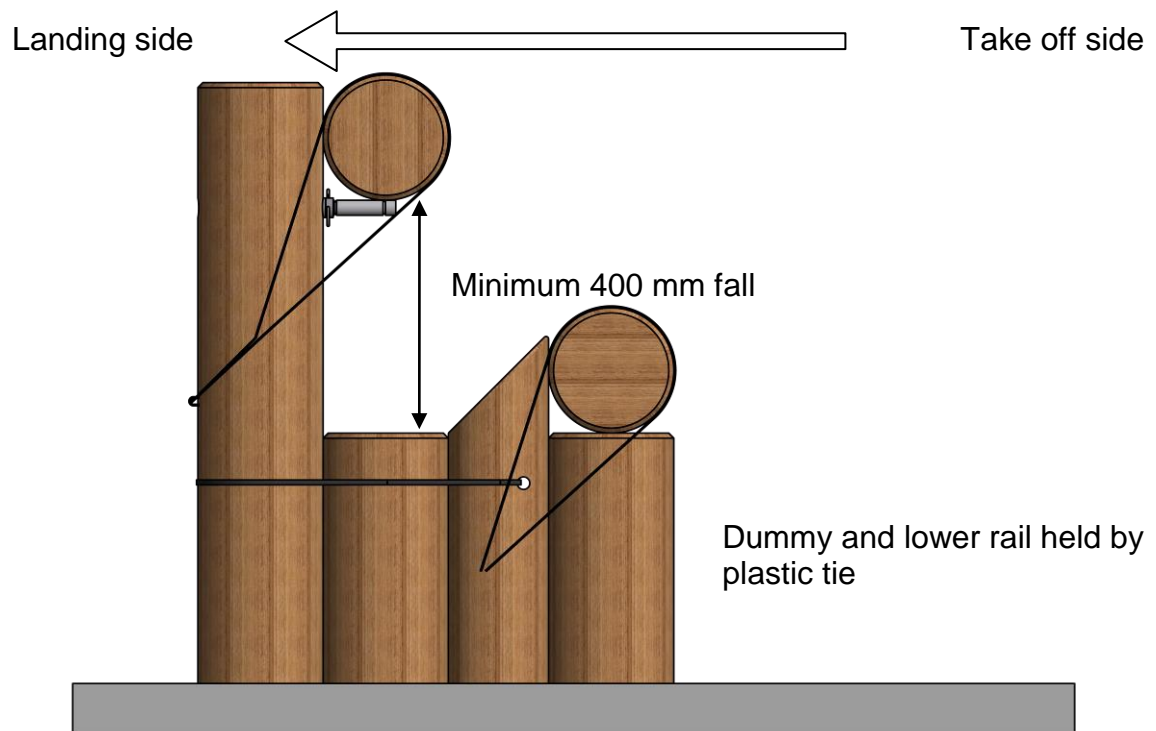

Figure 9 – Post and rail with lower rail

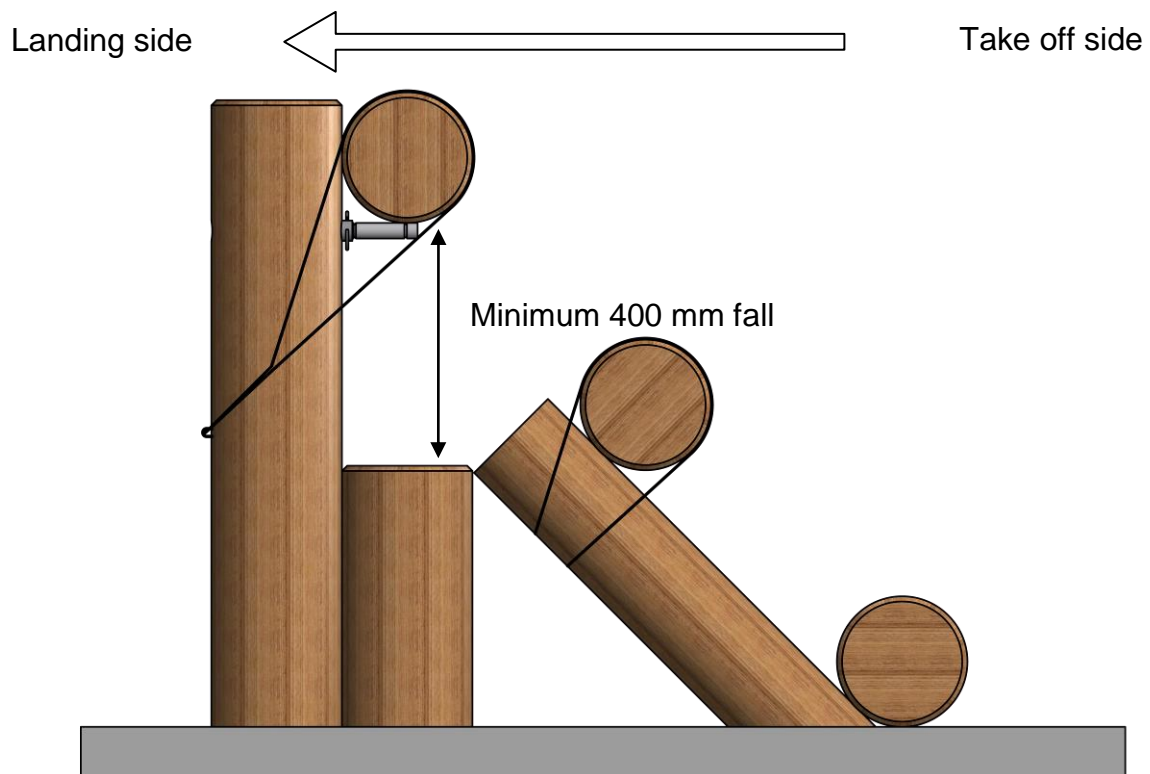
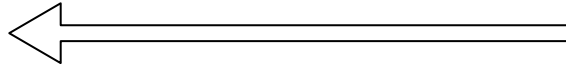
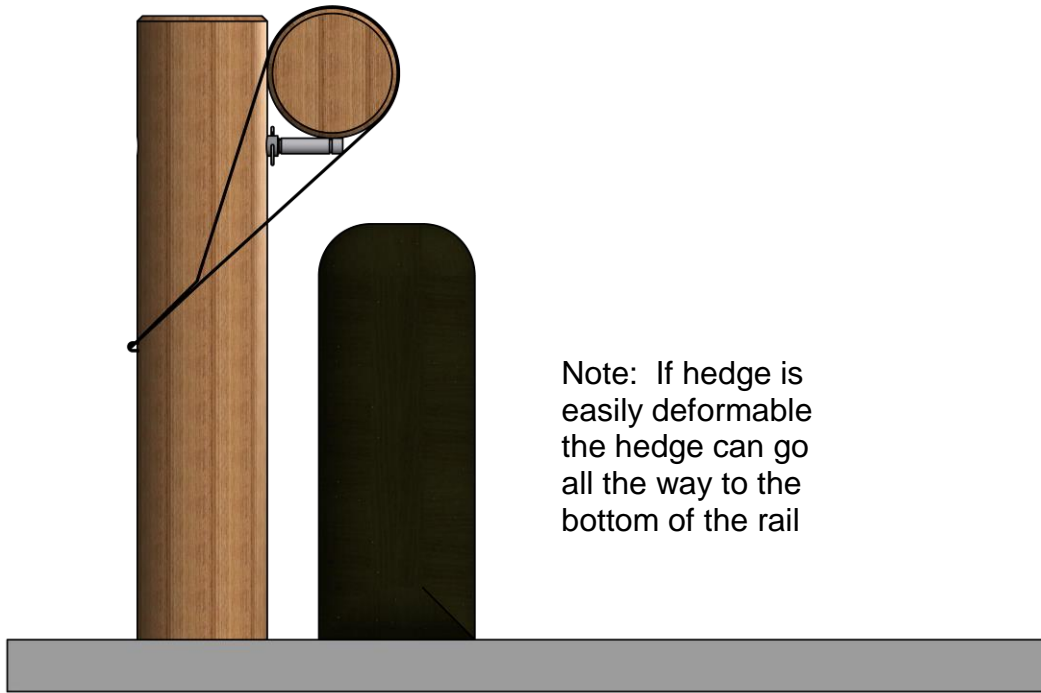

Figure 10 – Triple bar fence

Landing side



Take off side



Note: If hedge is easily deformable the hedge can go all the way to the bottom of the rail

Figure 11 – Hedge

A further common application is a corner obstacle. In this situation the two types of system are used together, reverse and conventional pinning.

The obstacle comprises of three posts as shown in Figure 12, the front rail is pinned in the conventional way on the take-off side of the fence while the back rail is reverse pinned.

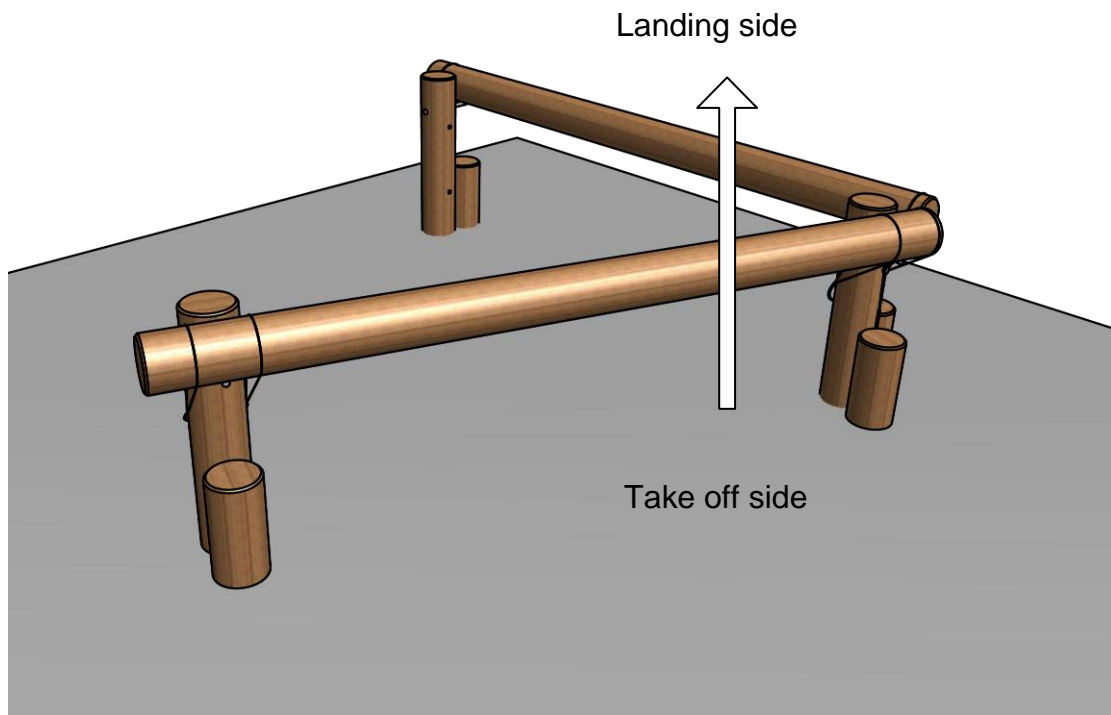

Figure 12 – Corner obstacle

IMPORTANT

A post and rail fence with a centre post is no longer an approved design.

Frangible pins must not be used as illustrated in Figure 13.

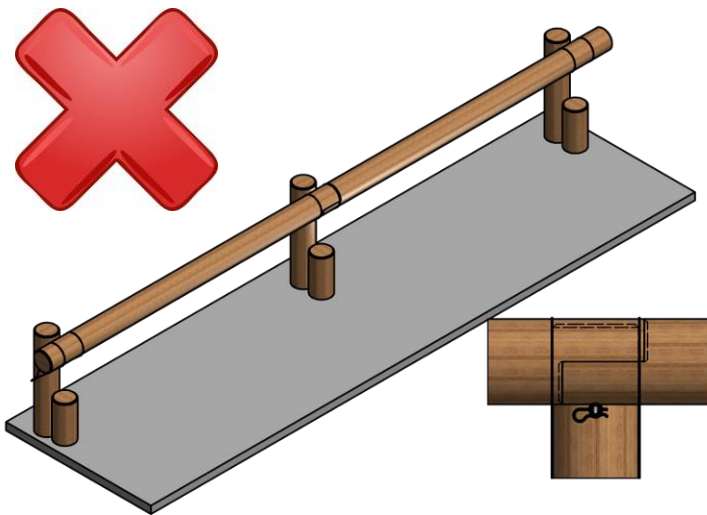
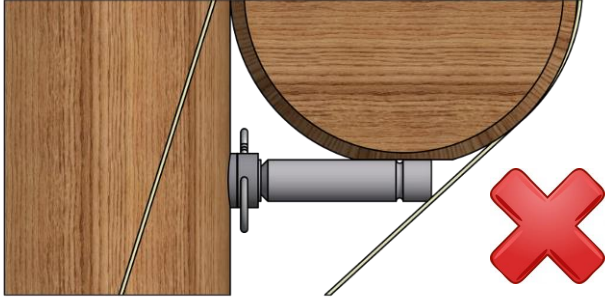
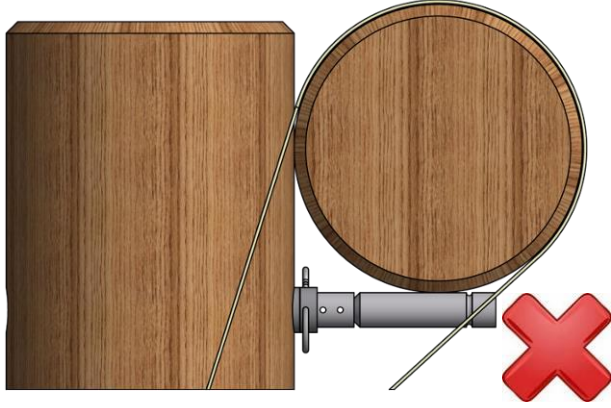

Figure 13 – Centre post

6 Troubleshooting

The following table details some common installation faults that should be avoided.

Issues	Comments
<p>Rail has a flat spot on the bottom which means the load is spread over the pin</p>	<p>As a result of a distributed load over the length of the pin, it will not fail at the design energy. As a result, the activation point of the system is compromised.</p>  <p>A point loading is required at the marker on the pin. In order to achieve this, a round rail is required. It is not advised to attach metal dowels to the rail as if it is knocked it is able to slip off, particularly with reverse pinning.</p>
<p>Pin in wrong position so that setting mark is not in line with the centre line of the rail.</p>	<p>If the pin is not in the correct position, the point loading from the will cause the pin to fail at an incorrect value. As a result, the activation point of the system is compromised.</p>  <p>Adjust the frangible pin in the sleeve to select a suitable hole to align the centre of the rail with the pin marker.</p>

Issue	Comments
<p>Poor fence construction.</p>	<p>It is important that fences are suitable constructed following good working practice and established cross country building techniques. Poor construction may result in the safety of the system being compromised.</p> <p>It is important that any fence is well secured to the ground. For a post and rail fence, the posts must be well secured within the ground for the system to work effectively and reliably. Repeated impacts may weaken post installation, and when used with reverse pinning, the post may turn in the ground if installation is insufficient.</p>
<p>Poor rail attachment with rope or cable system.</p>	<p>It is important that the rail is attached correctly to the post by means of roping for conventional pinning or by the cable system for reverse pinning. If instructions are not followed correctly, the safety of the system may be compromised.</p> <p>Cable tensioning is particularly important for reverse pinning:</p> <ul style="list-style-type: none"> • Over tensioning - vertical force on pin increased, as a result system may fail at a lower force than expected. • Under tensioning – rail is “loose” on pins and may slide along pin causing the system to fail at a lower force than expected.
<p>Rail is not able to drop by adequate height.</p>	<p>It is important that roping / cabling is able to allow the rail to drop by the appropriate height. It is also important that any other non-frangible parts of the fence do not hinder the rail dropping, for example an incorrectly dimensioned dummy post.</p>

7 Disposal of safety equipment

In the event of unexpected frangible pin failure or component failure, all parts must be returned to British Eventing Limited with a brief report as to what happened.

8 Storage / maintenance

The frangible pin and sleeves are manufactured from an aluminium alloy. There is a possibility that there may be a minor degree of corrosion. To minimise the potential for this it is recommended that either:

1. The pins are removed during the closed season, lightly oiled and stored in a dry place. They should be cleaned and lightly oiled prior to setting up the obstacle for the next season.
2. The pins are not removed from the obstacle during the closed season. They should be oiled at the end of the season, then cleaned and oiled again prior to setting up the obstacle for the next season.

The reverse pinning system is comprised of dissimilar materials. The anchor sleeve and pivot point sleeve are both manufactured from mild steel and the steel wire, rigging screw body and tightening bolt from stainless steel. There is a possibility that there may be a reaction between the dissimilar materials and as a result cleaning of components should be undertaken at the beginning and end of seasons.

It is important that the stainless steel tightening bolt and the bolt swaged to the steel rope used to tension the reverse pinning system are lubricated with copper slip or similar to prevent binding between the bolt and the rigging screw.